

# uTNT V3.0 GPS BT

Version of unit you have is specified on the serial number stick on the opposite site of your unit.

uTNT30LGT - uTNT V3.0 Light  
uTNT30STD - uTNT V3.0 Standard  
uTNT30PWR - uTNT V3.0 Power  
uTNT30GPS - uTNT V3.0 Internal GPS  
uTNT30BTH - uTNT V3.0 Internal Bluetooth  
uTNT30GBT - uTNT V3.0 Internal GPS and Bluetooth

For the new firmware, drivers, maintenance utility, manual and any details please refer to [www.elcom.gr](http://www.elcom.gr) or send e-mail to [support@elcom.gr](mailto:support@elcom.gr).

I/O Jacks and Cables description:

## RADIO CABLE – 2 mm jack

**BLACK** ----> **AGND**  
**RED** ----> **TX**  
**YELLOW** ----> **RX**  
**GREEN** ----> **PTT**

## GPS CABLE – 2 mm jack

**BLACK** ----> **DGND**  
**RED** ----> **GPS\_RX**  
**YELLOW** ----> **GPS\_TX**  
**GREEN** ----> **3.3V**

## Mini-USB Type A/B Pin assignment

Defined as part of the 'On-the-Go (OTG)' enhancement, features a single connector type (A/B) and peer-to-peer operation.

Pin	Name	Color	Notes
1	VBUS	Red	Power
2	D-	White	Data -
3	D+	Green	Data +
4	ID	-	Type B - NC
5	GND	Black	Ground

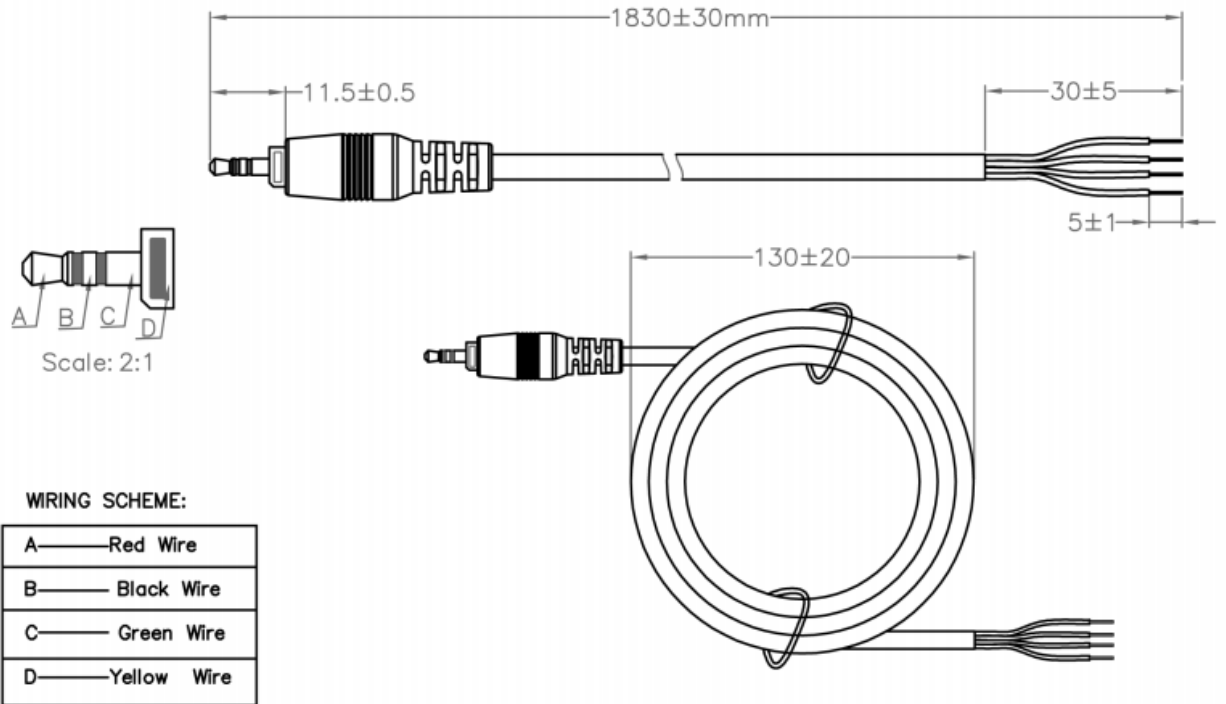

## Important Notices

Your uTNT V3.0 contains an internal 700/1400 mAh LIPO battery (except of version LGT) inside with independent and automatic special charger. It is charging automatically battery with special charging cycles every time you have connected your device to power supply or mini USB. Your internal battery is specially protected for overcharging or over discharging.

GPS socket provide independent power source of 3.3 VDC up to 100 mA. There is a special automatic PPTC electronic fuse to protect your device. This GPS power source is working always either you have connected your uTNT to mini USB or to external power supply.

If you are using external power supply please connect it to the mini USB power pins.

Your uTNT V 3.0 could be supplied form 5 V DC up to 26 V DC via mini USB socket. There is implemented reverse polarity protection, as also a special protection for possible ground loops, with PPTC fuses.

# uTNT Back Panel description

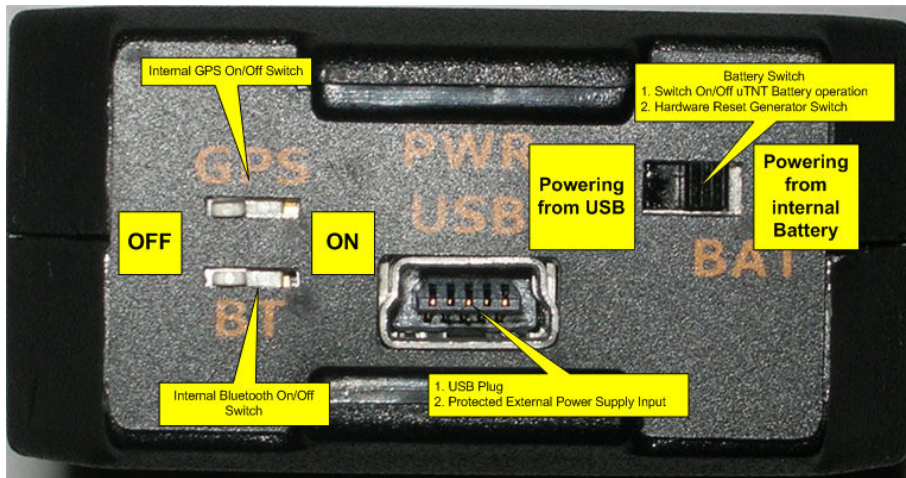

There are (depending to the version) 3 switches on the back panel of uTNTV3.0 and one connector.

1. Battery Switch
2. GPS switch
3. Bluetooth switch
4. mini USB/External Power supply input

Switch	Position	Functionality
Battery Switch	Powering from USB	It is automatically charging LIPO battery
	Powering from USB	It is powering uTNT from mini USB via USB or via external power supply connected to it
	Powering from USB	If power will be disconnected (USB or External Power) the uTNT will stop working
	Powering from internal Battery	If power will be disconnected (USB or External Power) the uTNT will continue working with internal battery
	Powering from internal Battery	It is automatically charging LIPO battery when external power or USB is connected.
	Powering from internal Battery	It switch on battery operation
	Switch from one position to other	is generating hardware reset
GPS switch	OFF	Switch internal GPS Off
	ON	Switch internal GPS On
	Switch from one position to other	is generating hardware reset
Bluetooth switch	OFF	Switch internal BT Off
	ON	Switch internal BT On
	Switch from one position to other	is generating hardware reset

## Emergency Uploading of New Firmware

In case when Maintenance Utility can not upload automatically new firmware; you will need to run Emergency Uploading Procedure. This could happen for the following reasons:

1. You have early version of uTNT with basic firmware only
2. Last uploaded version of Firmware is not valid and uTNT not responses
3. During uploading of firmware Maintenance Utility can not find bootloader

You will need then to generate hardware reset when Maintenance utility is trying to upload firmware.

Please notice that booting procedure before and after uploading is long and takes about 60 – 90 second.

1. Run Maintenance Utility
2. Locate on your uTNT device "Battery Switch" (the black one)
3. Make sure that "GPS Switch" and "Bluetooth Switch" are Off
4. Make sure that when you are doing uploading of the flash memory, your transceiver cable is removed (because there is possible to have unknown status on your PTT)
5. in the "Serial Port" menu point to the Virtual Serial port you have installed for this uTNT V3.0 (should be smaller than COM8)
6. Go to the "Flash Bios" Menu
7. Point to the file "uTNTP\_XXXXX.hex"
8. Press "Flash Bios" button on your Maintenance Utility Screen
9. Just after that move the "Battery Switch" on your uTNT to the next position (to any direction – left or right)
10. Moving of this switch will generate hardware reset and flashing of the firmware will start
11. You need to wait sometimes couple of second (30 - 60); during
12. Do not interrupt this procedure, as also during uploading of firmware do not run any other applications on your PC
13. You will see update of the bar on the screen
14. When it finished, you are ready
15. Wait until "Flash Bios" will be again working
16. Usually you need to wait after that for about 60 seconds until your uTNT will reboot
17. If needed repeat all procedure again

After that, you will always upload your new firmware just using only Flash button from your Maintenance Utility

For any support please ask to [support@elcom.gr](mailto:support@elcom.gr)

Thank you very much  
Elcom Research Team